

SAFEMEZZ®

Pallet Gate

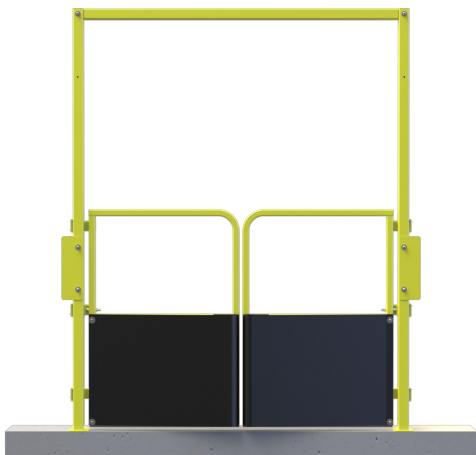

Installation Instructions/Operation and Maintenance Manual



Models:

All Models

Table of Contents:

Safety Precautions 2

Product Information 2

Operation 3

Installation Instructions 4

Replacement Parts List 7

Replacement Parts Diagram 8

Inspection and Maintenance..... 9

Warranty Certificate 11

Contact Information

Mail
 PS Safety Access
 1150 South 48th Street
 Grand Forks, ND 58201

Local Phone
 701.746.4519

Toll Free Phone
 877.446.1519

Website
 pssafetyaccess.com

Email
 4psinfo@psindustries.com

Hours of Operation
 8 A.M. to 5 P.M. CT
 Monday – Friday

IMPORTANT! Read entire Instruction and Operations Manual to become familiar with the product.

NOTICE This product is a fall protection product. The effectiveness of the product is directly related to the proper installation and operation of this product. Failure to properly maintain this product **will** affect performance.

Publication Notice

This manual has been compiled and published covering the latest product descriptions and specifications.

The contents of this manual and the specifications of this product are subject to change without notice.

PS Safety Access™ reserves the right to make changes without notice in the specifications and materials contained herein and shall not be responsible for any damages (including consequential) caused by reliance on the materials presented, including but not limited to typographical and other errors relating to the publication.

PS Safety Access and/or its respective suppliers may make improvements and/or changes in the product(s)/ service(s) offered and/or the program(s) at any time without notice.

Retain this manual for future reference.

If you would like to download a copy of this manual, please go to pssafetyaccess.com

Product registration is an essential step to protecting your product, register Online at psindustries.com/contact/register-your-product/



Safety Precautions

The following icons are used throughout this Manual.

- ▲ DANGER** Indicates an imminently hazardous situation which, if not avoided, will result in death or serious injury.
- ▲ WARNING** Indicates a potentially hazardous situation which, if not avoided, could result in death or serious injury.
- ▲ CAUTION** Indicates a potentially hazardous situation which, if not avoided, may result in minor or moderated injury.
- NOTICE** Indicates manufacturer's statement of additional information.
- IMPORTANT!** Indicates a required action.
- CRITICAL** Indicates a vital component to product performance.

Product Information

NOTICE Unauthorized modification of or to the Product voids this Limited Warranty. Authorized modifications, received in writing from PS Industries® Incorporated, as long as the modification is accomplished in strict accordance with PS Industries' instructions, does not void warranty. If this product is modified or altered without manufactures permission, manufacturer is no longer responsible for the product design, engineering, or performance and owner assumes all responsibility. To request product modifications contact PS Industries Incorporated, 1150 S. 48th Street, Grand Forks, ND 58201, phone 877-446-1519, email: 4psinfo@psindustries.com

I. General Information

- A. This manual contains information regarding installation, operation, and maintenance of the PS Safety Access' SafeMezz® Pallet Gate.
- B. PS Safety Access recommends that the owner implement a regular preventative maintenance program to inspect and maintain the Pallet Gate at a minimum, in accordance with the recommendations in this manual.

II. Operation Guidelines

- A. The Pallet Gate is designed to meet OSHA Railing Standard 1910.28 and 1910.29(b).
- B. Operation in a manner other than intended could result in damage or less than acceptable performance at time of need, for which the manufacturer will not be held responsible.

III. Safety Precautions

- A. Ensure opening is clear of all obstructions through the entire proposed travel of the Pallet Gate during operation.
- B. Comply with all OSHA and ANSI Safety Regulations and/or company safety policies when installing.

▲ DANGER Ensure area below installation is blocked off from personnel during installation, and mounting surface is capable of supporting all loading. Structural analysis of mounting surface is the responsibility of the owner.

IV. Storage Prior to Installation of Product

- A. Store materials in a dry, ventilated location. If outdoor storage is required, block materials and tarp in a tent-like arrangement, elevated above the product with open sides to allow airflow.

V. Installation Site Preparation

NOTICE Before starting site preparation and installation of the Pallet Gate, read the entire Operation and Maintenance Manual and review all installation instructions thoroughly.

- A. Clear work area of any debris.
- B. Ensure you have the necessary tools available.
- C. Obtain all required permits.
- D. Personnel: Determine the appropriate number of personnel required to perform installation and have them readily available at the project site (2-3 people recommended).

Product Information

VI. Pallet Gate Part List

A. Review inventory to ensure all parts are present for assembly/installation. Refer to part list below.

VII. Recommended Tools for Installation:

A. Tools:

1. One (1) $\frac{7}{16}$ " Wrench
2. One (1) $\frac{9}{16}$ " Wrench
3. One (1) Tape Measure
4. One (1) Level
5. Depending on anchoring configuration, additional tools may be required.

Pallet Gate Part List (As shipped)

ITEM #	DESCRIPTION	QTY
1	PLG;LEFT HAND ASSY	1
2	PLG;RIGHT HAND ASSY	1
3	PLG;ASSY CROSS BAR	1
4	PLG;VERTICAL POST PLATE	2
5	BOLT;HEX3/8"16X2 3/4	6
6	WASHER;FLAT 3/8"	12
7	NUT;NYLOCK 3/8"16	6

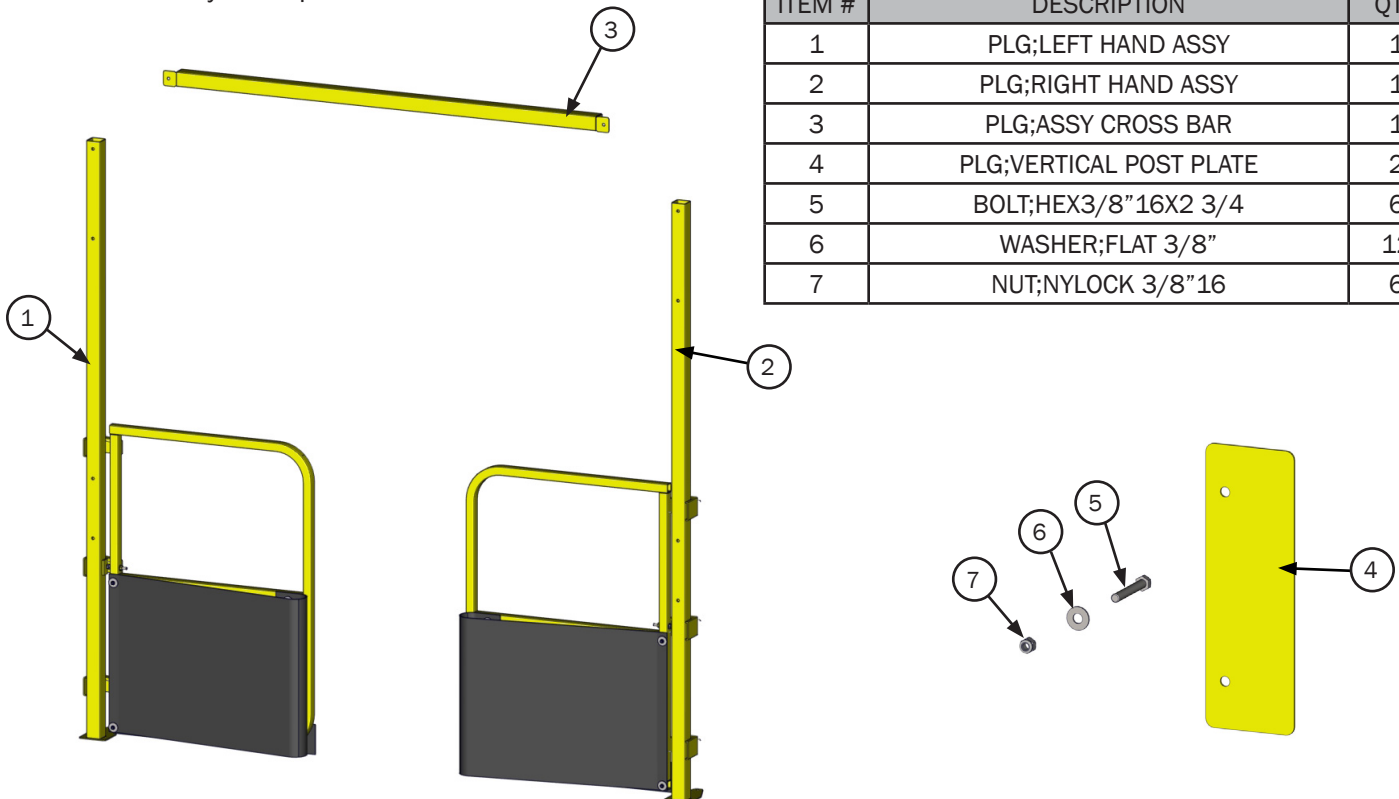

VIII. Operation

A. To Operate:

1. Forklift your pallet of material through the self-closing Pallet Gate and back away. The Gate closes up against your material, effectively protecting the mezzanine edge until the material is off-loaded or the pallet is removed from the opening. Then the Gates spring closes, all the time protecting the opening.

▲ WARNING Do NOT force components if they do not operate freely.

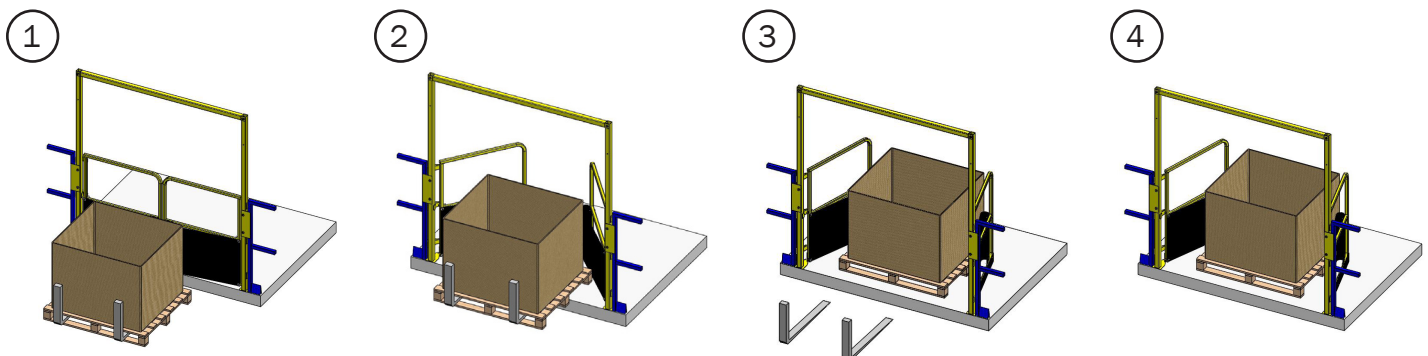

Installation

IX. Installation Preparation

NOTICE Mounting anchors provided by others, NOT PS Safety Access ($\frac{3}{8}$ " anchors as appropriate for the mounting surface are recommended).

IMPORTANT! The Bumpers on the Gate MUST be located on the side to which the material will be loaded from (refer to Illustration I).

NOTICE To protect the Powder Coat finish, lay on cardboard.

STEP 1. Assemble the Pallet Gate as shown below.

- Lay out Pallet Gate horizontally on the floor, making sure swing direction is correct (refer to Illustration I).
- Determine the maximum height of the material being loaded through the Pallet Gate. Factory locations of 66" and 78" clear openings are provided. Field drill holes if alternate height is needed.
- Install the Cross Bar using the provided fasteners $\frac{3}{8}$ " x $2\frac{3}{4}$ " hex bolt, $\frac{3}{8}$ " washers, and $\frac{3}{8}$ " nylock nut. (Refer to Detail A).

IMPORTANT! Be sure the tab on the cross bar is on the same side which the material will be loaded from (refer to Detail A). The Cross Bar MUST be used in the installation. If it is determined the Cross Bar will not work in your application, consult PS Safety Access for recommendations. Do NOT tighten until Columns have been plumbed and squared.

Step 1 Illustration I

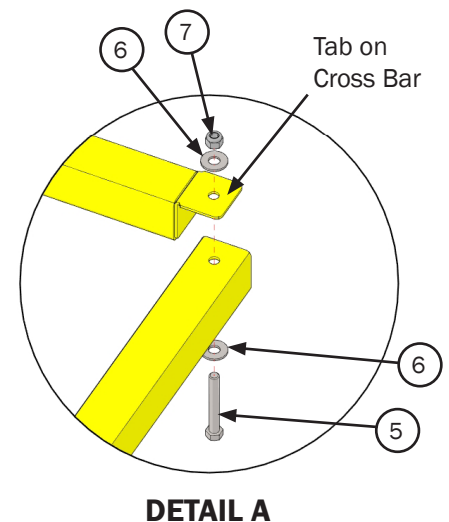
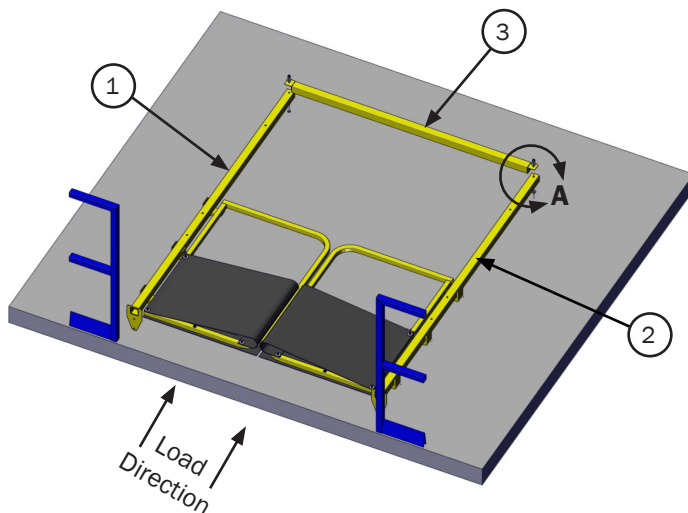

▲ CAUTION Next step requires two (2) personnel.

STEP 2. Lift Pallet Gate Assembly into a vertical position and set into location.

- Before anchoring, be sure the Gate is plumb and square with a $\frac{5}{8}$ " nominal gap between the Gates for clearance (refer to Illustration I).
- Attach the Floor Brackets of the Vertical Post Assembly to the floor, as shown in Illustration II. Anchors provided by others, NOT PS Safety Access.

IMPORTANT! Ensure Floor Bracket does NOT overlap the vertical face of the mounting surface.

Installation

Step 2 Illustration I

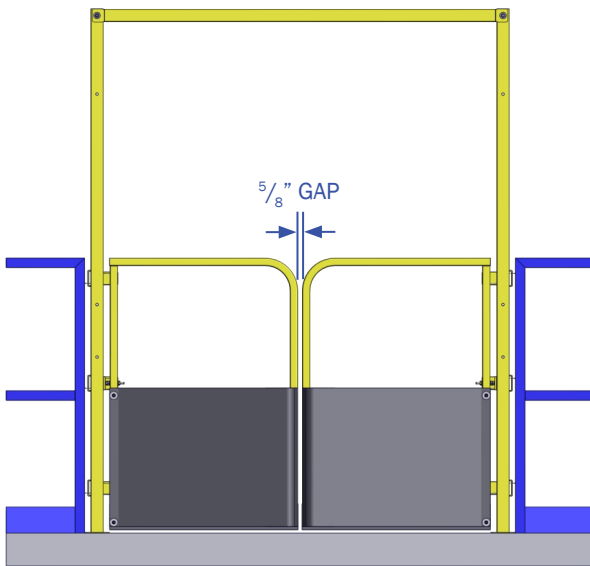

Step 2 Illustration II

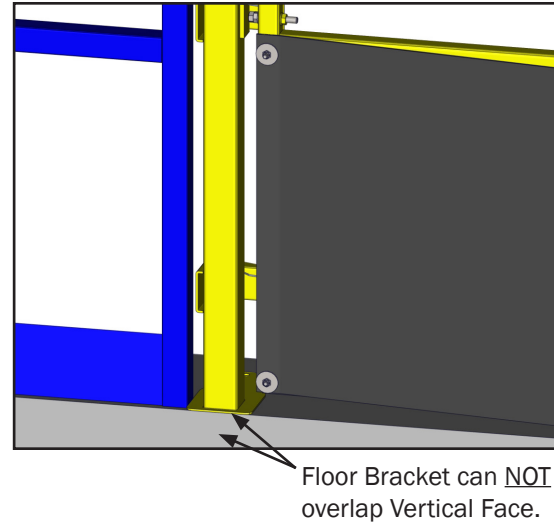

STEP 3. Attach Vertical Post Plate to the predetermined holes in the Column.

- Secure using provided $\frac{3}{8}$ " x $2\frac{3}{4}$ " hex bolts, $\frac{3}{8}$ " washers, and $\frac{3}{8}$ " nylock nuts.
- The Plate can be attached on either side of the Column, if needed.
- Field attach the Plate to the existing structure, shimming as necessary.

IMPORTANT! The Vertical Post Plate MUST be used in the installation. If it is determined the Plate will not work in your application, consult PS Safety Access for recommendations.

Step 3 Illustration I

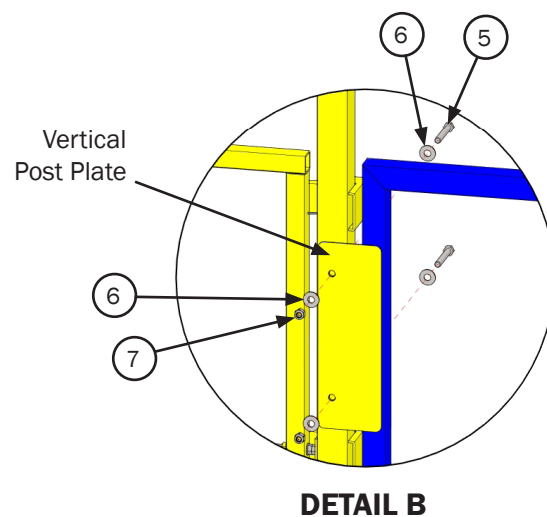
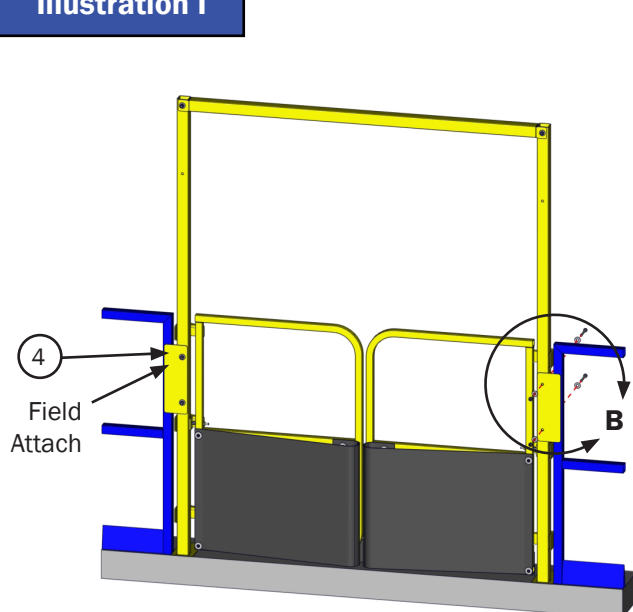

Installation

STEP 4. Align Gates by adjusting the $\frac{3}{8}$ " bolt and nylock nut as shown below.

**Step 4
Illustration I**

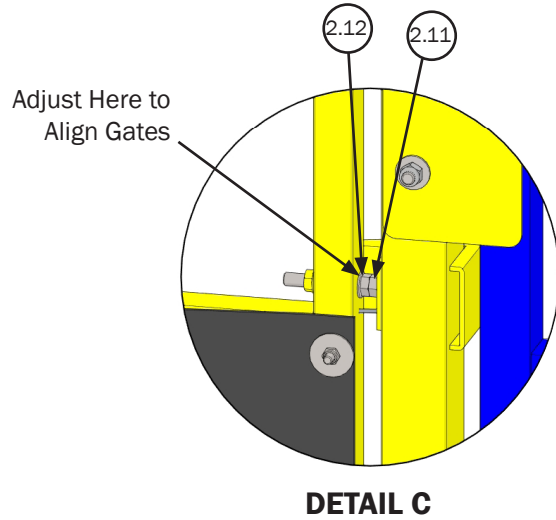
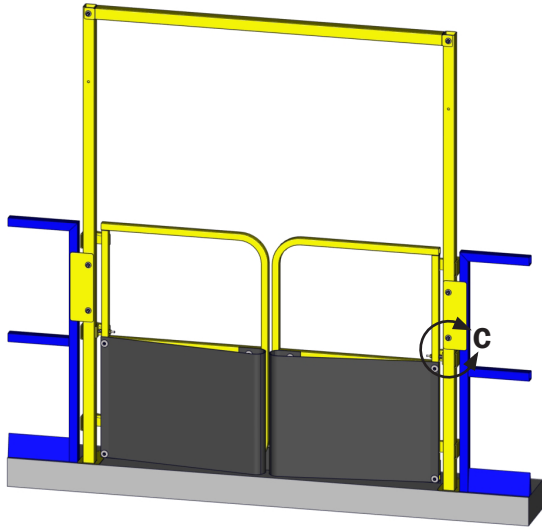

**Step 4
Illustration II**

TOP VIEW

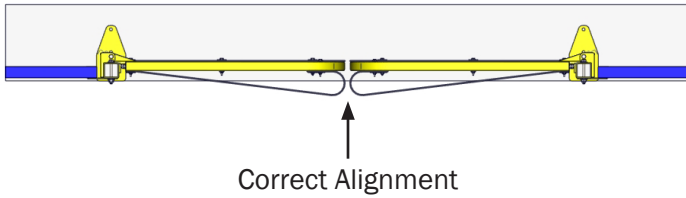

**Step 4
Illustration III**

TOP VIEW

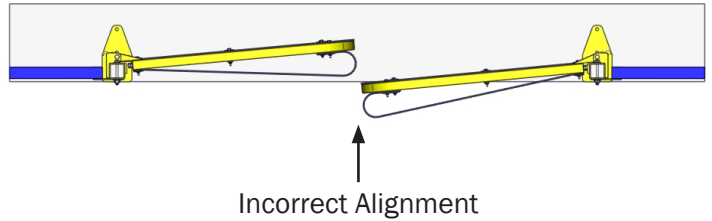

Replacement Parts List

X. Replacement Parts List

- A. These Replacement Parts Lists are for all SafeMezz® Pallet Gate Models.
 B. The Parts Diagram is located on Page 8.

Finish Options	
SS	Stainless Steel
PCY	Powder Coat Safety Yellow

**TO ORDER PARTS CONTACT PS SAFETY ACCESS AT
877.446.1519 or 4psinfo@psindustries.com**

Replacement Parts List				
ITEM #	DESCRIPTION	QTY	SS	PCY
1	REFER TO HARDWARE VARIANT			
1.1	REFER TO HARDWARE VARIANT			
1.2	REFER TO HARDWARE VARIANT			
1.3	BOLT;HEX1/4"20X2	5	500380	500378
1.4	NUT;NYLOCK JAM 1/4"20	5	503200	501124
1.5	WASHER;FLAT 1/4"	3	508032	501939
1.6	WASHER;FENDER 1/4" X 1-1/4"	7	509177	509108
1.7	BOLT;HEX5/16"18X3	3	500433	500431
1.8	LSG;WASHER NYLON .875X.367.04	6	501018	501018
1.9	NUT;NYLOCK 5/16"18	3	501121	501126
1.10	LSG;TORSION SPRING, ST. STL	3	501659	501659
1.11	BOLT;TAP3/8"16X2 1/2	1	503201	500452
1.12	NUT;FLANGE 3/8"16	1	501086	501085
2	REFER TO HARDWARE VARIANT			
2.1	REFER TO HARDWARE VARIANT			
2.2	REFER TO HARDWARE VARIANT			
2.3	BOLT;HEX1/4"20X2	5	500380	500378
2.4	NUT;NYLOCK JAM 1/4"20	5	503200	501124
2.5	WASHER;FLAT 1/4"	3	508032	501939
2.6	WASHER;FENDER 1/4" X 1-1/4"	7	509177	509108
2.7	BOLT;HEX5/16"18X3	3	500433	500431
2.8	LSG;WASHER NYLON .875X.367.04	6	501018	501018
2.9	NUT;NYLOCK 5/16"18	3	501121	501126
2.10	LSG;TORSION SPRING, ST. STL	3	501659	501659
2.11	BOLT;TAP3/8"16X2 1/2	1	503201	500452
2.12	NUT;FLANGE 3/8"16	1	501086	501085
3	REFER TO HARDWARE VARIANT			
4	PLG;VERTICAL POST PLATE	2	503196	502210
5	BOLT;HEX3/8"16X2 3/4"	6	503199	500406
6	WASHER;FLAT 3/8"	12	501945	501947
7	NUT;NYLOCK 3/8"16	6	501119	501120

Hardware Variant for PLG-60 Gates				
ITEM #	DESCRIPTION	QTY	SS	PCY
1	PLG;LEFT HAND ASSY-60"	1	511558	511560
1.1	PLG;BUMPER - 60"	1	501233	501233
1.2	PLG;TOE BOARD-60"	1	502191	502509
2	PLG;RIGHT HAND ASSY-60"	1	511559	511561
2.1	PLG;BUMPER - 60"	1	501233	501233
2.2	PLG;TOE BOARD-60"	1	502191	502509
3	PLG;ASSY CROSS BAR-60"	1	503246	502509

Hardware Variant for PLG-72 Gates				
ITEM #	DESCRIPTION	QTY	SS	PCY
1	PLG;LEFT HAND ASSY-72"	1	511562	511564
1.1	PLG;BUMPER - 72"	1	501234	501234
1.2	PLG;TOE BOARD-72"	1	502192	502192
2	PLG;RIGHT HAND ASSY-72"	1	511563	511565
2.1	PLG;BUMPER - 72"	1	501234	501234
2.2	PLG;TOE BOARD-72"	1	502192	502192
3	PLG;ASSY CROSS BAR-72"	1	503195	502510

Hardware Variant for PLG-96 Gates				
ITEM #	DESCRIPTION	QTY	SS	PCY
1	PLG;LEFT HAND ASSY-96	1	514133	513297
1.1	PLG;BUMPER - 96"	1	513302	513302
1.2	PLG;TOE BOARD-96"	1	513303	513303
2	PLG;RIGHT HAND ASSY-96	1	514137	513304
2.1	PLG;BUMPER - 96"	1	513302	513302
2.2	PLG;TOE BOARD-96"	1	513303	513303
3	PLG;ASSY CROSS BAR-96"	1	514140	513307

Replacement Parts Diagram

XI. Replacement Parts Diagram

- A. This Parts Diagram is for all SafeMezz® Pallet Gate Models.
- B. Bumper and Right Vertical Post shown translucent for better viewing of hardware.
- C. The Replacement Parts Lists are located on Page 7.

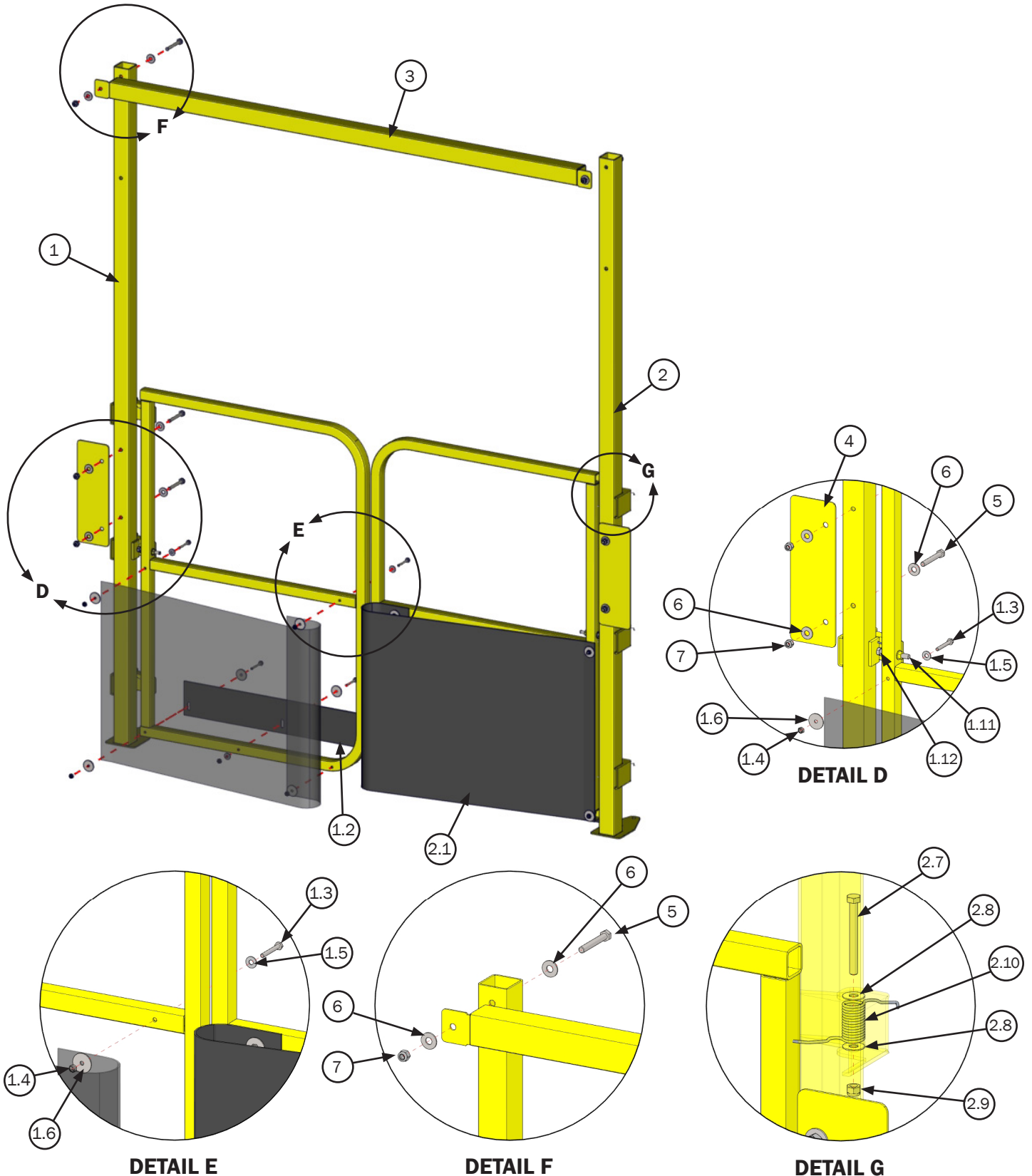

Inspection and Maintenance

XII. Inspection and Maintenance (Minimum Annually)

IMPORTANT! Consult parts list before replacing fasteners, as all have specific design load requirements. Only use like items for replacement.

A. Gate/Frame:

1. Inspect components for damage and misalignment. Adjust, repair, or replace as needed, to meet original design tolerance.
2. Check gate for proper alignment with catch. Adjust as necessary to achieve proper alignment.

B. Fasteners and mechanical connections

1. All fasteners must be in place and adjusted to their original design standard. Replace any damaged components.
2. Check all mounting connections, making sure they meet original design standards (refer to instructions).

C. Finishes

1. Inspect and clean finishes periodically.
2. Touch up repair finishes, or refinish as necessary to protect the structural integrity of the Pallet Gate.
3. The PCY Pallet Gate comes with a polyester powder coat finish. Use finish materials compatible with powder coat. Follow paint manufacturers' instructions for prep and touch-up.

D. Housekeeping

1. To ensure your product continues to operate and last, upon completion of proper installation, complete the following:
 - a. Clean all surfaces.
 - b. If project is ongoing, protect installed products until final completion of project.
 - c. Touch-up, repair, or replace damaged components.
2. Ensure the area is clear of debris and interferences while swinging the gates.

E. Labels and Placards:

1. Inspect all labels and placards.
2. Replace any labels and placards which are unreadable/missing.

Inspection and Maintenance Log

CRITICAL Periodic Inspection and Maintenance Required. Inspect at minimum annually.

Date Installed: _____
 Product: _____
 Model Number: _____
 Serial Number: _____

Opening Identifier/ Number: _____
 Location: _____

DATE INSPECTED	INSPECTED BY <i>(Print & Sign)</i>	INSPECTION ITEMS NOTED	CORRECTIVE ACTION	CORRECTED BY <i>(Print & Sign)</i>

PS INDUSTRIES® INCORPORATED – LIMITED WARRANTY

Limited Warranty: Subject to the terms of this Limited Warranty, PS Industries® Incorporated warrants to the original user or consumer (the “Owner”) of a PS Industries product (the “Product”) that, for a period of one (1) year from date of shipment, the Product will be free from defects in material and workmanship under normal use and service, and provided the Product is installed, operated and maintained in accordance with instructions supplied by PS Industries. The terms and limitations of this Limited Warranty apply to all repaired or replacement Products for a term equal to the balance of the warranty remaining on the Product that was repaired or replaced as of the date of such repair or replacement. Register online at: www.psindustries.com/contact/register-your-product

PS Flood Barriers™ Product Warranty Registration: For PS Flood Barriers™ Products, this Limited Warranty will only be valid if the Owner completes the Warranty Registration Form provided within thirty (30) days of Product installation. To request a copy of the Warranty Registration Form, contact PS Industries Incorporated, 1150 S. 48th Street, Grand Forks, ND 58201, phone 877-446-1519, email: 4psinfo@psindustries.com. Register online at: www.psindustries.com/contact/register-your-product/ Additional Warranty Registration Forms can be downloaded at www.psfloodbarriers.com/download-center/

Warranty Exclusions: Notwithstanding anything to the contrary, this Limited Warranty does not cover any of the following:

1. Normal wear and tear (including, but not limited to, normal wear and tear to gaskets and weather seals); damage or accidents resulting from freight damage, from failure to follow precautionary safety measures, or applied paint failure; abuse, misuse or unauthorized modification of the Product; misapplication; improper installation; or any defects, damage or other harm that is not the result of the acts or omissions of PS Industries.
2. Cost of field labor or other charges incurred by Owner in removing and/or re-affixing the Product or any part or component thereof.
3. Transportation costs.

Unauthorized modification of or to the Product voids this Limited Warranty. Authorized modifications, received in writing from PS Industries, as long as the modification is accomplished in strict accordance with PS Industries’ instructions, does not void warranty. To request product modifications contact PS Industries, 1150 S. 48th Street, Grand Forks, ND 58201, phone 877-446-1519, email: 4psinfo@psindustries.com.

Claim Procedure: To make a claim under this Limited Warranty, the claim must be received by PS Industries before the expiration of the above stated Limited Warranty period together with proof of purchase. Contact PS Industries at the address shown below.

PS Industries Incorporated	Toll Free: 877-446-1519
Attention: Warranty	Phone: 701-746-4519
1150 S. 48th Street	Fax: 701-746-8340
Grand Forks, ND 58201	E-mail: 4psinfo@psindustries.com

An authorized PS Industries representative must be given a reasonable opportunity to inspect and investigate the alleged Product defect prior to any work being done that affects the Product or its installation. PS Industries reserves the right to charge reasonable amounts for travel and labor associated with investigation of claims. PS Industries may also require photographs of the alleged Product defect or return of the Product or part to a designated PS Industries location, freight prepaid. A return goods authorization must be received prior to the return of the Product or part. Please contact PS Industries to determine the designated location for return and to obtain the return material authorization.

Exclusive Remedy: In the event of a warranty claim that PS Industries determines to be covered by this Limited Warranty, PS Industries will replace or repair, at PS Industries’ discretion, the Product or any part of the Product found to be defective.

Disclaimers: The above warranty and remedy is the sole express warranty and remedy given by PS Industries on its Product. No warranties or representations at any time made by any representative from PS Industries shall vary or expand the provisions hereof. TO THE EXTENT PERMITTED BY LAW, ALL EXPRESS AND IMPLIED WARRANTIES (INCLUDING IMPLIED WARRANTIES OF MERCHANTABILITY, FITNESS FOR A PARTICULAR PURPOSE AND NON-INFRINGEMENT) OTHER THAN THE EXPRESS LIMITED WARRANTY SET FORTH ABOVE ARE EXPRESSLY DISCLAIMED. UPON THE EXPIRATION OF THE ABOVE STATED LIMITED WARRANTY PERIOD, ANY AND ALL APPLICABLE IMPLIED WARRANTIES, INCLUDING, WITHOUT LIMITATION, WARRANTIES OF MERCHANTABILITY, FITNESS FOR A PARTICULAR PURPOSE AND NON-INFRINGEMENT, ARE DISCLAIMED. SOME STATES DO NOT ALLOW LIMITATION ON HOW LONG AN IMPLIED WARRANTY LASTS, SO THE ABOVE LIMITATION MAY NOT APPLY TO OWNER.

LIABILITY LIMITATION: In no event will PS Industries’ liability to Owner or any other person or entity exceed the price paid to PS Industries for the defective Product. IN NO EVENT SHALL PS INDUSTRIES BE LIABLE TO OWNER OR ANY OTHER PERSON OR ENTITY FOR INCIDENTAL, CONSEQUENTIAL, INDIRECT OR SPECIAL DAMAGES OF ANY DESCRIPTION, WHETHER ARISING OUT OF WARRANTY (INCLUDING ANY IMPLIED WARRANTIES) OR ANY OTHER CONTRACT, STRICT LIABILITY, NEGLIGENCE OR OTHER TORT, OR OTHERWISE, INCLUDING ARISING FROM INSPECTION OR REMEDY DELAYS. SOME STATES DO NOT ALLOW THE EXCLUSION OR LIMITATION OF INCIDENTAL OR CONSEQUENTIAL DAMAGES, SO THE ABOVE LIMITATION AND EXCLUSION MAY NOT APPLY TO OWNER.

THIS WARRANTY GIVES OWNER SPECIFIC LEGAL RIGHTS AND OWNER MAY ALSO HAVE OTHER RIGHTS, WHICH VARY FROM STATE TO STATE.



877.446.1519

4psinfo@psindustries.com | pssafetyaccess.com
1150 South 48th Street | Grand Forks, ND 58201

Product Registration:
psindustries.com/contact/register-your-product